

interface

FORCE MEASUREMENT SOLUTIONS.

Installation & User Manual

9825



9825 Installation & User Manual

Info Icons



Note:

"**Note**" means essential information that will help you use the device more effectively.



Caution:

"**Caution**" means this may cause damage to your device or data loss if you do not follow the instructions.



Warning:

"**Warning**" means potential danger. **Example:** property damage, personal injury or even death.

Pre Installation Warnings



Warning:

This device must be installed and connected by a professional electrical staff with the power supply disconnected for safe and dependable operation.



Warning:

This device cannot be used in an unsafe environment. Example: Where explosion protection is required.

Table of Contents

Unpacking & Installation	1
Unpacking	1
Storage & Installation	1
Connections	2
Power Connections	2
Load Cell Connections	2
Serial I/O Device Connections	4
USB Port Connections	4
Analog Output Connections	4
Relay Input/Output Control Connections	5
Basic Operation	6
Power On	6
Display Details	6
Keypad Details	7
System Configuration	8
Menu Tree	8
Menu Descriptions	8
Calibration Procedures	10
Industrial Interfaces	12
USB Interface Communication	12
Analog Output Interface	12
I/O Control Applications	13
Setpoint Application	13
Alarm Application	13
Indicator Info	14
Software Version	14
Error Codes	14
Appendix	15
Appendix 1: Command Output Format 1 - Continuous Mode (ASCII)	15
Appendix 2: Command Output Format 1 - Demand Mode (ASCII)	16
Appendix 3: Condec Format Output (Condec)	17
Specifications	18
Warranty	19

Unpacking & Installation

Unpacking:

Please follow these inspection procedures after unpacking the product:

- Check the product to ensure that there was no damage in transit.
- Check the following list and confirm that all the items are in the carton:
 - 9825 Digital Indicator
 - External Connecting Terminals
 - Clamping Strips & Anchor Nuts
 - 9825 External Power Supply
 - 9825 Grounding Cable Assembly
 - 9825 Installation & User Manual
 - Product Qualification Certificate

Storage & Installation:

The 9825 indicator must be stored in a dry, dust-free environment before use. Storage temperature is -20°C to $+65^{\circ}\text{C}$ (-4°F to $+149^{\circ}\text{F}$), working environment temperature is -10°C to $+104^{\circ}\text{F}$ ($+14^{\circ}\text{F}$ to $+104^{\circ}\text{F}$), relative humidity no more than 95% (Non-Condensing).

The 9825 digital indicator uses panel installation, which requires the thickness of the cabinet's front panel to be no more than 4mm. Before installation, remove the two mounting screws from the indicator's clamping strips, then remove the clamping strips. Push the indicator into the opening on the cabinet, then reinsert the clamping strips. Gently tighten the two mounting screws.

Indicator structure and physical dimensions (mm)

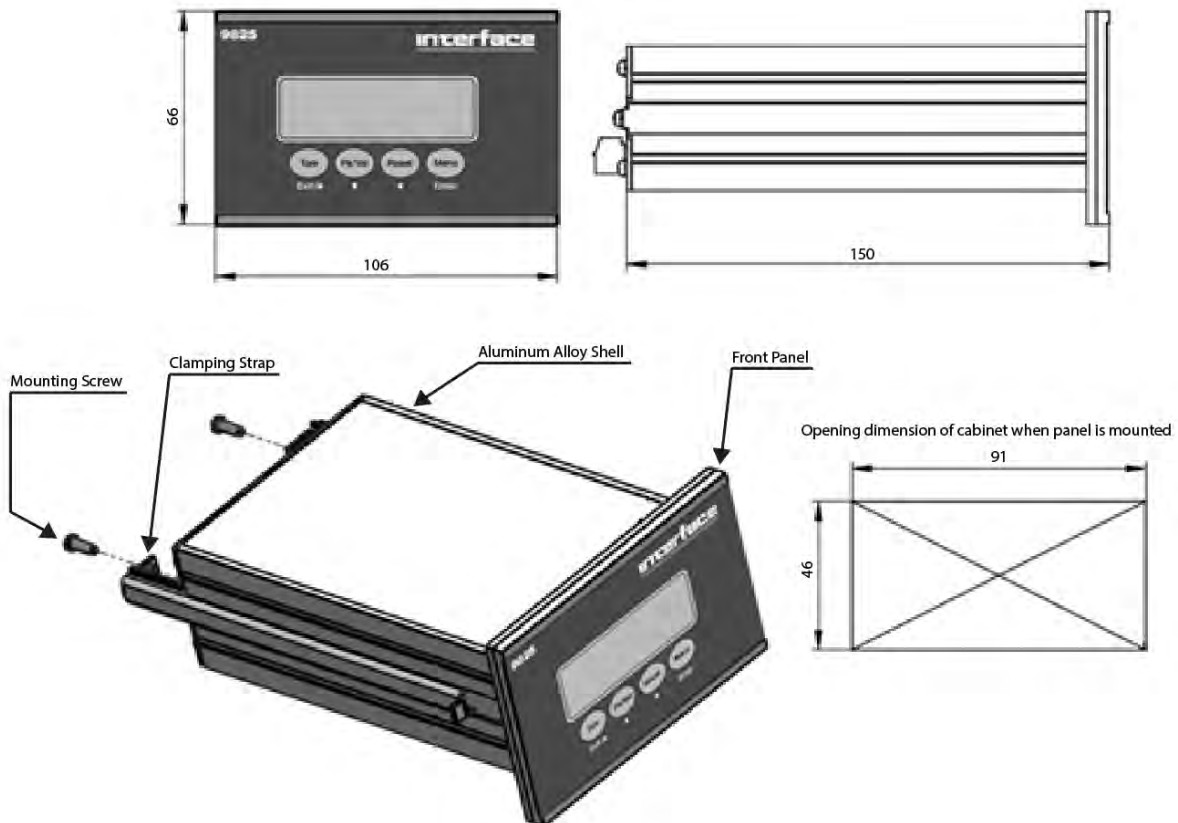

Connections:

Power Connections:

The 9825 has an input range of 9VDC to 36VDC. The maximum electrical power consumption of the 9825 is 6W (8W Peak). The unit is shipped with an external 24VDC linear power supply and a grounding cable assembly. The GND Terminal should be routed to the grounding lug on the rear of the 9825 housing and then to earth using the provided grounding cable assembly in order to optimize signal stability.

Use the screw down terminals to secure the power supply leads and grounding cable to the 3 position connector in the following configuration:

Pin Assignment:

1 = VDC +

2 = VDC -

3 = GND



Warning:

Verify that the power supply connections are correct before powering on.



Note:

Make sure that the power cord does not pose a potential obstacle or tripping hazard. Only use approved accessories and peripherals.

Load Cell Connections:

The 9825 indicator uses a 6-wire load cell signal connection. This indicator provides a 4.5 volt DC excitation voltage to the load cell(s). The voltage difference between +SIG and -SIG is about 0 ~ 9mV when connected to a load cell with a 2mV/V output, and about 0 ~ 13.5mV when connected to a load cell with a 3mV/V output. The 9825 indicator can drive up to six (6) 350-ohm load cells (or the equivalent resistance of all load cells connected in parallel is higher than 87 Ω).

If the application requires the 9825 to be connected to multiple load cells, please use a junction box.



Note:

This product does not contain a junction box. If a junction box is necessary for your application, we recommend Interface Model JB104SS as an approved accessory.

The load cell cable requires a shield which must be properly grounded to ensure maximum stability. High quality cable is recommended. Be sure to route the load cell cable away from high voltage / power cables. The maximum length allowed for the load cell or junction box cable is shown in the following table:

	24 AWG	20 AWG	16 AWG
Connect to 1-350 Ω load cell	200 m	300 m	400 m
Connect to 3-350 Ω load cells	60 m	150 m	200 m
Connect to 4-350 Ω load cells	40 m	100 m	120 m

Sensor Input Terminal Pin Assignment:

Wire Name	Port Number	Definition	Voltage Range
+ EXC	1	Positive excitation	4.5V
+ SEN	2	Positive sense	4.5V (after connecting to a load cell)
+ SIG	3	Positive signal	Slightly higher than 2.25V (after connecting to a load cell)
SHLD	4	Shield ground	NA
- SIG	5	Negative signal	Slightly lower than 2.25V (after connecting to a load cell)
- SEN	6	Negative sense	0V (after connecting with a load cell)
- EXC	7	Negative excitation	0V

Four-Wire Analog (Load Cell) or (Junction Box) Connection:

9825

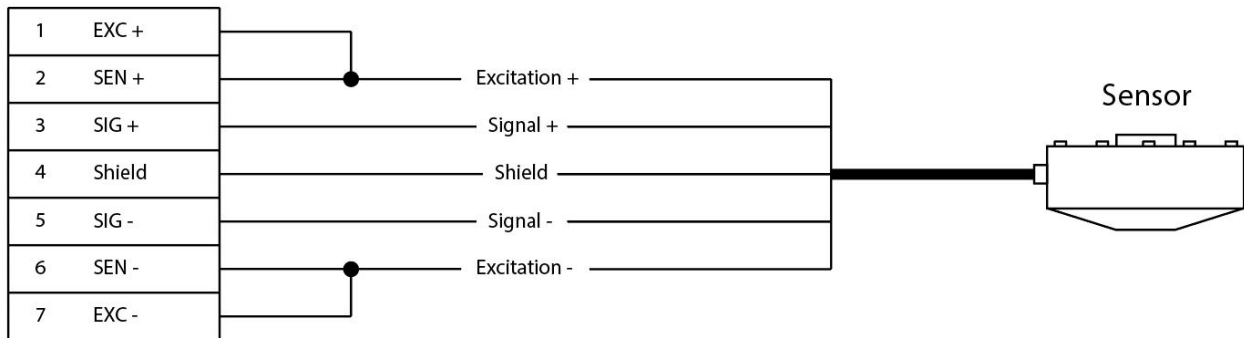

Six-Wire Analog (Load Cell) or (Junction Box) Connection:

9825

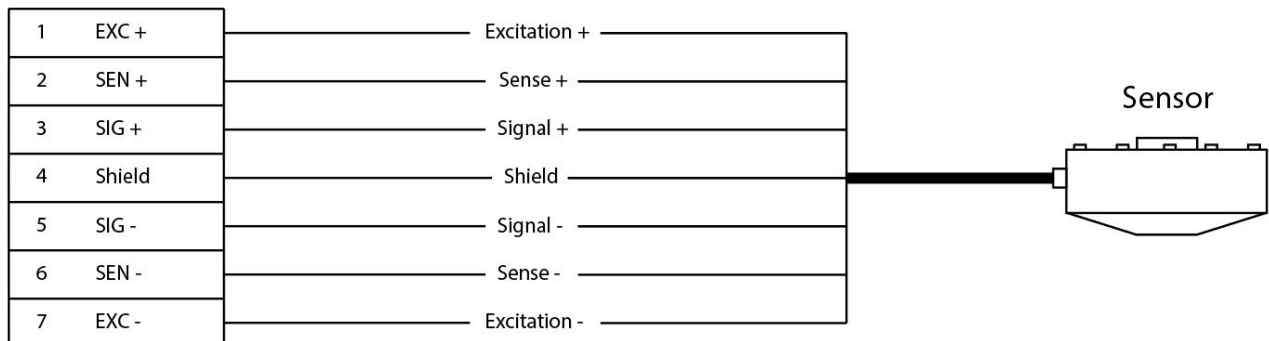

Serial I/O Device Connections:

The 9825 indicator comes standard with one USB port.

USB Port Connections:

The 9825 indicator comes standard with a MINI-USB port that can be connected to a PC. This USB port is designed for data communication and firmware upgrades.

Analog Output Connections:

Use the JP1 pin header on the internal analog option board to configure the analog output for current output (4-20mA, 0-24mA) or voltage output (0-10V, 0-5V). Please note that voltage and current outputs cannot be used at the same time. We suggest using a PLC or PC to monitor the analog output calibration.

Configure the voltage or current output as follows. Output type is selected in the Analog Out Setup menu, under the Output Type submenu.

Voltage output: Select either 0-5V or 0-10V. Use the Analog + & Analog - terminals.

Current output: Select either 0-24mA or 4-20mA. Use the Analog + & Analog - terminals.

Relay Input/Output Control Connections:

The Output Connections:

The 9825 optional I/O control port is relay-based and can be used with an AC or DC power supply. The DC power supply range is 24VDC to 100VDC. The AC power supply range is up to 220VAC.

The COM terminal can be connected to the positive or negative of the power supply. The maximum power output of each relay is 90W / 5A.

Output control interfaces and load connection diagram:

9825

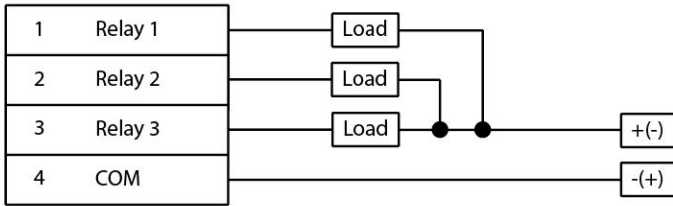

Output control interfaces and PLC connection diagram:

9825

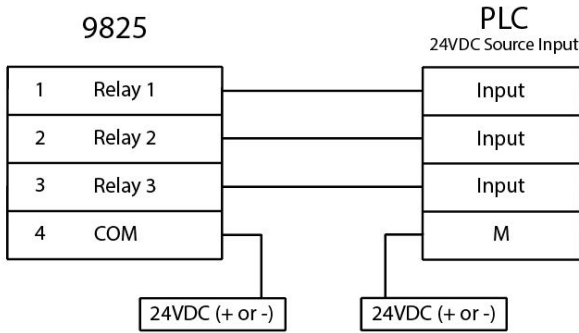

The Input Connections:

The input interfaces are isolated, passive inputs. The interfaces can be connected to many control control keys (Buttons), and the wiring is as follows.

9825

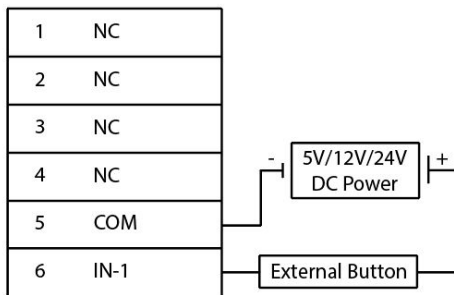

Basic Operation

Power On:

The display will show the Interface logo followed by the Device Mode and Firmware Version. After that, the current force value will be displayed.

Display Details:

The 9825 utilizes a 128 x 32 dot OLED display with adjustable LED back-light. The table below summarizes the display annunciators.

Basic Force Display:



Force Display with Tare Function Active:



Force Display with Relay Function Active:



Symbol	Display
T	Indicates that a push-button tare load has been established in the system
lb	Indicates that the unit of the displayed load is in pounds
kg	Indicates that the unit of the displayed load is in kilograms
~	This light is on whenever the measurement is unstable.
⊠	Status #1 active for selected Relay mode. Please refer to “I/O control interface and function” section
⊞	Status #2 active for selected Relay mode. Please refer to “I/O control interface and function” section

Keypad Details:



Keypad Functions:

Tare (Exit, ↑):

- **When in display mode (Tare Function)**
 - Pressing this key sets force value to zero (sets tare).
 - If tare is already set, pressing this key removes tare.
- **When in the setup menu (Exit Function)**
 - Return to a previous menu.
 - Increase the value when used as directional key (↑).
 - Hold to exit setup menu.

PK/Val (↓):

- **When in display mode (PK/Val Function)**
 - Cycle among real time, peak and valley display modes.
- **When in the setup menu (↓ Function)**
 - Enter sub-menu.
 - Decrease a value when used as a directional key (↓).

Reset (←):

- **When in display mode (Reset Function)**
 - Resets peak and valley values.
- **When in setup menu (← Function)**
 - Moves left when used as directional key.

Menu (Enter):

- **When in display mode (Menu Function)**
 - Hold this key until buzzer sounds to enter the setup menu.
- **When in setup menu (Enter Function)**
 - Saves current setting.

System Configuration

Menu Tree:

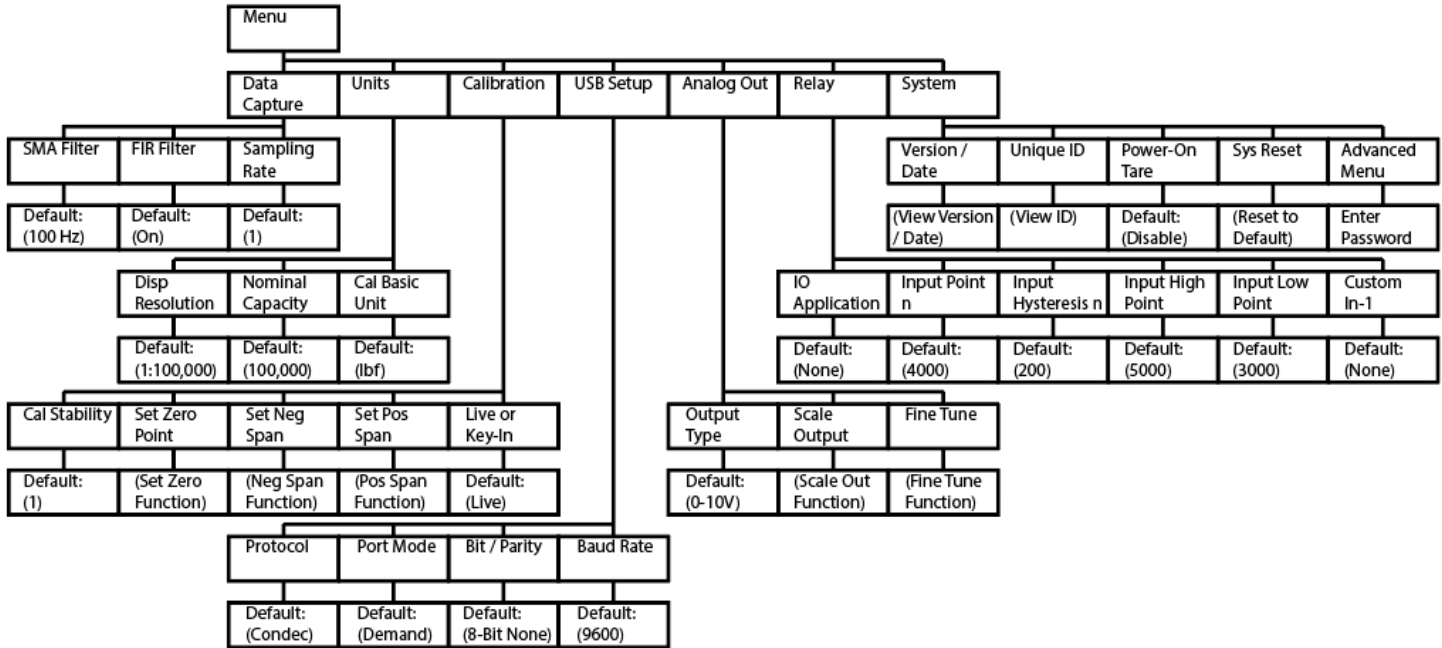

Warning:

Do not access the Advanced Menu unless instructed to do so by a qualified technician.

Menu Description:

Menu	Sub-Menu	Description	Default	Options
Data Capture	Sampling Rate	Number of Samples per second.	100Hz	30, 40, 50, 60, 75, 80, 100, 120, 150, 170, 200, 240, 300, 400, 600, 1200Hz
	FIR Filter (Finite Impulse Response)	Reduces the influence of nearby electrical or mechanical noise sources.	On	Off, On
	SMA Filter (Simple Moving Average)	Smooths signal by averaging samples over a given span.	1	Integer values from 1 to 100
Units	Cal Basic Unit	Select engineering units displayed	lbf	lbf, ozf, N, kN, g, kg, UNIT_NONE
	Nominal Capacity	Sets display output range	100,000	Integer values from 1 to 100,000
	Disp Resolution	Set decimal placement and increments	1:100,000	Menu options are based on Nominal Capacity value

Calibration	Live or Key-In	Set calibration type	Live	Live, Key-In
	Set Pos Span	Set span from zero to positive capacity		Press ↓ and enter to start sequence Fixture Press ↓ to start sequence
	Set Neg Span	Set span from zero to negative capacity		
	Set Zero Point	Set zero		
	Cal Stability	A greater value can produce higher accuracy calibration points but will require a more stable mV/V input signal during calibration as well.	1	Integer values from 0 to 320 represent the number of samples averaged when capturing a calibration point. Larger values = greater stability required
USB Setup	Baud Rate	Serial communication rate in bits per second	9600	2400, 4800, 9600, 19200, 38400, 57600, 115200
	Bit / Parity	Set Binary format and check bit	8-bit None	8-bit None, 8-bit Even, 7-bit Even, 7-bit Odd
	Port Mode	Set port mode	Demand	Demand, Continuous
	Protocol	Set Protocol (see protocol descriptions in the appendix)	Condec	Condec, ASCII
Analog Out	Output Type	Set Analog output type	0-10V	4-20mA, 0-10V, 0-5V, 0-24mA
	Scale Output			Adjust Low and High points using keypad
	Fine Tune			Adjust 0%, 50%, 100% output points using keypad
Relay	IO Application		None	None, Setpoint, Alarm
	Input Point n (Setpoint)		4000	Adjust values using keypad
	Input Hysteresis n (Setpoint)		200	
	Input High Point (Alarm)		5000	
	Input Low Point (Alarm)		3000	
	Custom In-1		None	None, Reset Key, Tare Key, Print Key
System	Version / Date	Display firmware version and date		Press ↓ to view
	Unique ID	Display Unique ID		
	Power-On Tare		Disable	Off, On
	Sys Reset	Reset to default settings.		Press ↓ to execute
	Advanced Menu	Password Required		Enter Password 336699 to access the Advanced Menu

Calibration Procedures:

Calibration Overview:

The 9825 Indicator can be calibrated by using either a Live calibration method or a Key-In calibration method. It is important to set the Nominal Capacity Value before beginning calibration.

Live Calibration:

The Live calibration method produces the best possible system accuracy. This method requires one of the following:

- The load cell being paired with the 9825 Indicator will be connected to the instrument while a series of nominal force loads are applied to calibrate the instrument.
- A load simulator will be connected to the 9825 Indicator while a series of simulated mV/V loads are applied to calibrate the instrument.

Live calibration is accomplished by setting the Positive Span, Negative Span and Zero. To execute a Live calibration, follow the steps below:

1. Press and hold the Menu button to enter the setup menu. A beep will sound as the setup menu is activated.
2. Using the → (Menu) button, scroll until Calibration is displayed on the screen. Press the ↓ (Pk/Val) button to enter the calibration sub-menus.
3. Using the → (Menu) button, scroll until Set Pos (or Neg) Span is displayed on the screen. Press the ↓ (Pk/Val) button to initiate the calibration process.
4. The term Fixture will show on the screen. At this point the load cell should be set into its fixturing, but with no additional calibration loads applied. If a simulator is being used for the Live calibration, connect the simulator, but set its value to 0mV/V. Press the Menu (Enter) button to save this point.
5. After the Fixture value has been set, the term C1 (calibration point #1) will appear on the screen. The user should set the numerical field so that it displays the nominal force load that is about to be applied. Once this value has been input and the applied force load has stabilized, pressing the Menu (Enter) button will capture this point.
6. The C2 term will then appear. If the user would like to add another calibration point (up to six are possible) they can repeat the actions in Step 5. If the user would like to end the calibration, they should leave the numerical field as 0 and press the Menu (Enter) button.



Note: if the calibration was unsuccessful, an error message will appear:

- "Err2" : There is not enough signal from the load cell. This is most commonly caused by incorrect wiring or a damaged load cell.

Repeat this process in the opposing polarity, than proceed to Zero calibration.

Zero Calibration:

1. Press and hold the Menu button to enter the setup menu. A beep will sound as the setup menu is activated.
2. Using the → (Menu) button, scroll until Calibration is displayed on the screen. Press the ↓ (Pk/Val) button to enter the calibration sub-menus.
3. Using the → (Menu) button, scroll until Set Zero Point is displayed on the screen.
4. At this point, the Zero Calibration is ready to begin. Be sure the load cell is connected and in an unloaded state. If using a simulator, be sure that the simulator is set to 0mV/V. Press the ↓ (Pk/Val) button to initiate the Zero Calibration. Dashed lines will be displayed at the bottom right of the screen to indicate that the 9825 is capturing the zero point.

Key-In Calibration:

The Key-In calibration method is typically only used in emergency cases when the indicator cannot receive a Live calibration. The Key-In method uses a single point to establish the span of the load cell. It ignores load cell nonlinearity and any asymmetry between the opposing loading modes.

To execute a Key-In calibration, follow the steps below:

1. Press and hold the Menu button to enter the setup menu. A beep will sound as the setup menu is activated.
2. Using the → (Menu) button, scroll until Calibration is displayed on the screen. Press the ↓ (Pk/Val) button to enter the calibration sub-menus.
3. The Live or Key-In sub-menu is the first Calibration sub-menu and should be displayed on the screen. Press the ← (Reset) button to change the flashing value from Live to Key-In. Press the Menu (Enter) button to save this setting.
4. Press the → (Menu) button to change the sub-menu to Rated Output. Press the ↓ (Pk/Val) button to enter the Rated Output sub-menu.
5. Enter the sensitivity of the load cell into the numerical field. This is typically the mV/V output of the load cell at its rated capacity. Press the Menu (Enter) button to save this value.
6. Press the → (Menu) button to change the sub-menu to Sensor Capacity. Press the ↓ (Pk/Val) button to enter the Sensor Capacity sub-menu.
7. Enter the rated capacity of the load cell into the numerical field. Press the Menu (Enter) button to save this value.
8. Press the → (Menu) button to change the sub-menu to Set Zero Point. User should perform a Zero Calibration as detailed above.

Industrial Interfaces

USB Interface Communication:

The 9825 indicator can connect to a PC via USB cable. First a USB driver must be installed on the PC to access the 9825. Measurement data can be accessed by using a terminal emulation application such as HyperTerminal. The USB Port output has Two fixed strings: ASCII and Condec.

Analog Output Interface:

Analog Output Calibration:

The mode of the Analog Output can be selected from its Output Type sub-menu. There are four modes of analog output: 4-20mA, 0-24mA, 0-5V and 0-10V. Please refer to the wiring section for the proper jumper setting of the optional analog output board. To calibrate the Analog Output, follow the steps below:

Scale Output:

1. While within the Analog Output menu, scroll to Scale Output and press the ↓ (Pk/Val) button to initiate the Scale Output sequence.
2. Scale Output is set by inputting a Low and High force value. To set a given value, use the numerical field on the screen to input the desired force. The first character can be used to switch the sign convention from + to - and back. Press the ↓ (Pk/Val) button to save the setting.

Fine Tune:

Before performing this part of the device setup, the Analog Output of the 9825 should be connected to whatever instrument will be accepting and measuring the analog signal.

1. In the Analog Output setup menu, scroll to Fine Tune and press the ↓ (Pk/Val) button to initiate the Fine Tune sequence.
2. The screen will display "0%", which indicates the lowest point of the analog scale. For voltage outputs, this is 0VDC. For current outputs this is either 0mA (0-24mA) or 4mA (4-20mA).
3. By adjusting the numerical value on the screen, the Analog output will be Fine Tuned. The digit furthest to the left creates the greatest change in output, while the digit furthest to the right creates the smallest change in output. Adjust this number until the measured value on the connected meter or PLC shows the minimum point on the analog scale. Press Menu (Enter) to save this value and proceed.
4. Repeat this process for the 50% point. For a 0-5V setting the output will be 2.5V. For a 4-20mA setting the output will be 12mA and so on.
5. Repeat this process for the 100% point.











Notes:

- The analog output mode setup to 4mA-20mA: If the load 0kg, the voltage output is 0. If the load is the full range of the scale, than the voltage output is 24mA.
- The analog output mode setup to 0-10V: If the load 0kg, the voltage output is 0. If the load is the full range of the scale, than the voltage output is 10.8V.

I/O Control Applications:

SetPoint Application:





The following conditions should occur when you use SetPoint application:



1. When the load is less than the value of "Input Point 1":
 - The  symbol will show on the display.
 - The OUT-1 relay will close.Otherwise, the  symbol will show on the display and the OUT-1 relay will open.
2. When the load is less than the value of "Input Point 2", But greater than the value of "Input Point1":
 - The  symbol will show on the display.
 - The OUT-2 relay will close.Otherwise, the  symbol will show on the display and the OUT-2 relay will open.
3. When the load is less than the value of "Input Point 3", but greater than the value of "Input Point2":
 - The  symbol will show on the display.
 - The OUT-3 relay will close.Otherwise, the  symbol will show on the display and the OUT-3 relay will open.
4. When the load is less than the value of "Input Point 4", but greater than the value of "Input Point 3":
 - The  symbol will show on the display.
 - The OUT-4 relay will close.Otherwise, the  symbol will show on the display and the OUT-4 relay will open.



Alarm Application:

The loads of the four configurable Alarm points must follow this formula:

Input ExtraHigh > Input HighPoint > Input LowPoint > Input ExtraLow

1. When the load is less than the value of "Input ExtraHigh":
 - The  symbol will show on the display
 - The alarm will sound
 - The OUT-1 relay will close
 - The display will send a warning messageOtherwise, the  symbol will show on the display and the OUT-1 relay will open.
2. When the load is less than the value of "Input ExtraHigh", but greater than the value of "Input HighPoint":
 - The  symbol will show on the display
 - The alarm will sound
 - The OUT-2 relay will close
 - The display will send a warning messageOtherwise, the  symbol will show on the display and the OUT-2 relay will open.

3. When the load is less than the value of "Input LowPoint", but greater than the value of "Input ExtraLow":
 - The  symbol will show on the display
 - The alarm will sound
 - The OUT-3 relay will close
 - The display will send a warning message
 Otherwise, the  symbol will show on the display and the OUT-3 relay will open.

4. When the load is less than the value of "Input ExtraLow":
 - The  symbol will show on the display
 - The alarm will sound
 - The OUT-4 relay will close
 - The display will send a warning message
 Otherwise, the  symbol will show on the display and the OUT-4 relay will open.

Indicator Info

Software Version:

This Information can be accessed from the main menu under Menu_System_Version/Date.

- Software Version:
- Last Update:

<pre> VERSION: VER1.4.0 UPDATA: 2021-12-17 </pre>

Error Codes:

- error!!:** The setting value is over limit when setting in Menu.
- ERR0:** The input span value is over the indicator capacity, when calibrating span.
- ERR1:** The input span value is lower than one percent of the indicator capacity, when calibrating span.
- ERR2:** When calibrating span, the delta AD counts are less than the counts required for the indicator setting accuracy. Need to reduce the indicator setting accuracy.
- Err-003:** Load cell line is not connected well. There is no REF voltage supplied.
- Err-004:** It may be a problem with the ADC chip.
- Err-005:** The +S/-S voltage is over the ADC chip measuring range.

Appendix

Appendix 1: Command Output Format 1 - Continuous Mode (ASCII)

In this mode of communication, the indicator transmits the data frame continuously. The load value in the frame is expressed in ASCII.

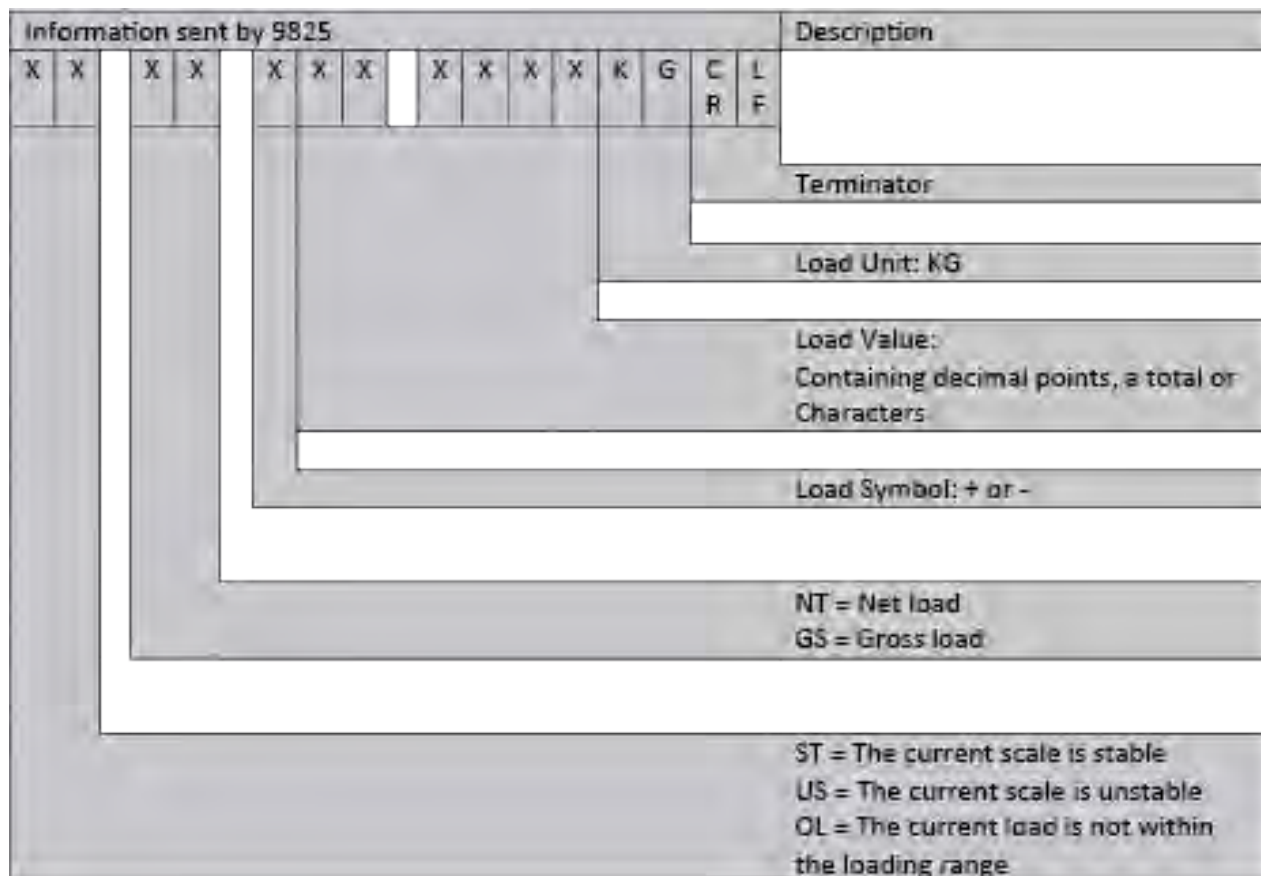

Appendix 2: Command Output Format 1 - Demand Mode (ASCII)

This host device (PC) will output demand command through the serial ports when the scale is in the normal loading status.

The demand command format is shown below:

R (0x52)	E (0x45)	A (0x41)	D (0x44)	CR (0x0D)	LF (0x0A)
-------------	-------------	-------------	-------------	--------------	--------------

The serial output data format is as follows:

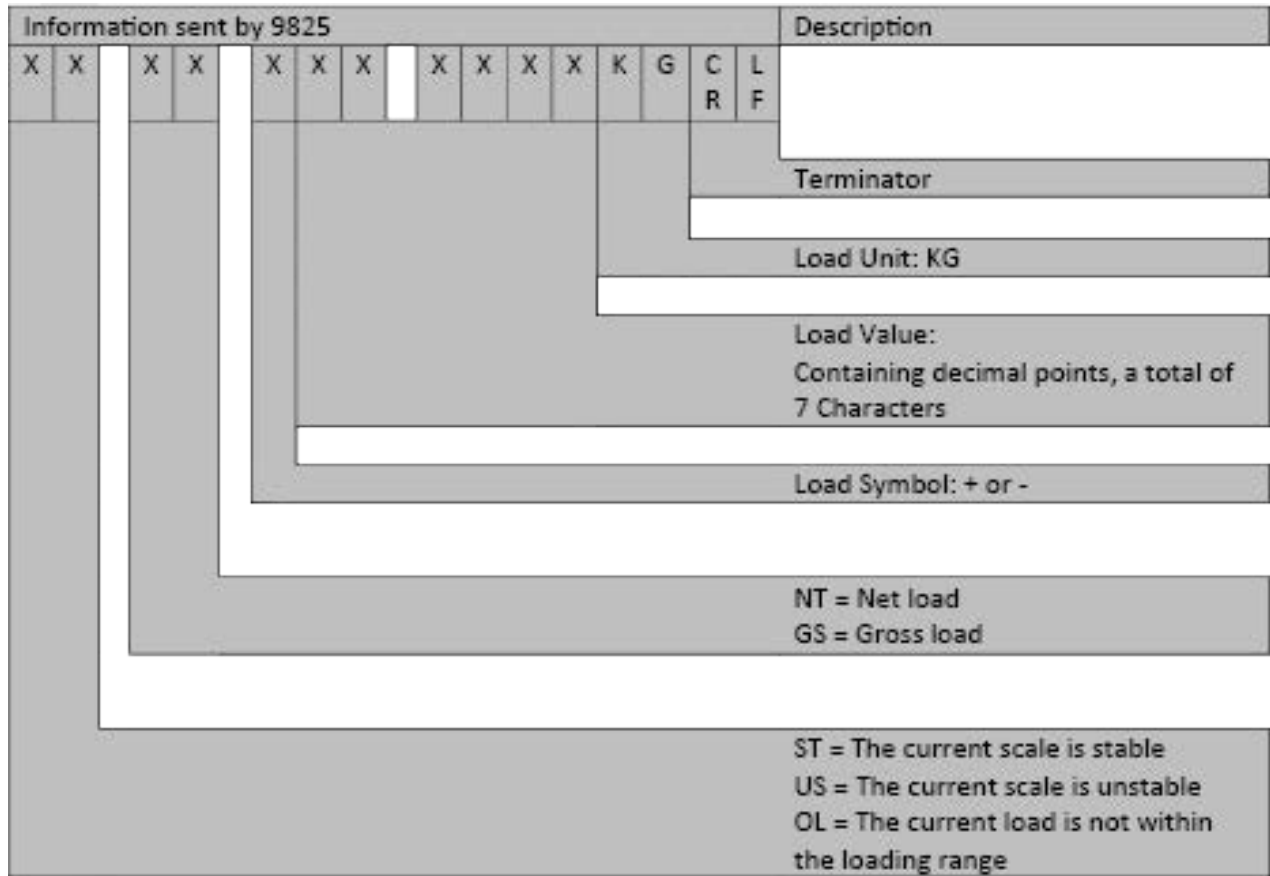

Appendix 3: Condec Format Output (Condec)

Condec Demand Output:

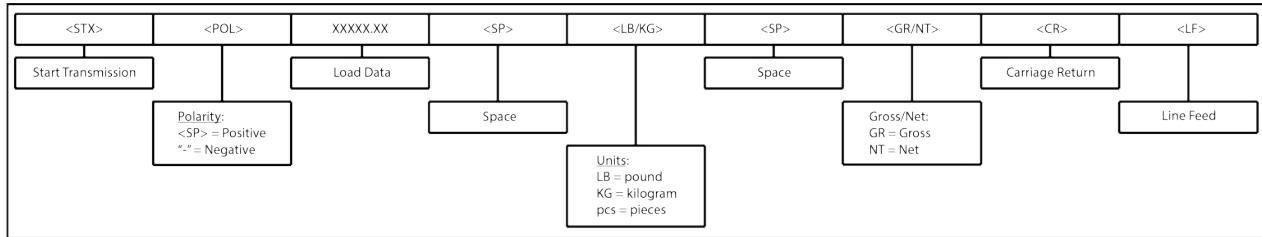

Demand Commands:

- "P" > Print
- "T" > Tare
- "Z" > Zero
- "G" > Gross
- "N" > Net

Condec Continuous Output:

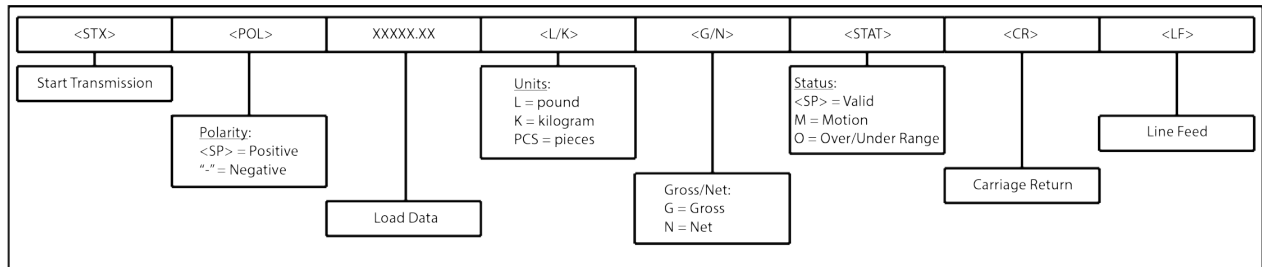

Function Address	Description
40001	Reads the instrument gross value
40002	Reads the instrument tare value
40004	Reads the instrument status word
Bit 0	0: Plus sign 1: Minus sign
Bit 1	0: Unstable 1: Stable
Bit 2	0: Normal 1: Overflow
Bit 3	Decimal point: 010 = 0; 011 = 0.0; 100 = 0.00; 101 = 0.000; 110 = 0.0000; 111 = 0;
Bit 4	
Bit 5	
Bit 6 ~ 9	Undefined
Bit 10	0 = lb 1 = kg
Bit 11 ~ 15	Undefined

Function Address	Description
40003	Bit 0: Write 1 = tare the scale
	Bit 1: Write 1 = clear the scale
	Bit 2: Write 1 = zero the scale
	Bit 3 ~ 7: Unidentified

 **Note:** The starting address 40001 of MODBUS is not suitable for SIEMENS soft.

Specifications

EXCITATION		
Excitation Voltage – VDC		4.5
Current – mA		100
PERFORMANCE		
Maximum Display Counts		±999,999
Internal Resolution Counts		1,000,000
Signal Input Range – mV/V		±4.5
Sensitivity – μ V/count		0.03
Readings Per Second - MAX		1000
Latency	Variable up to 20ms (Affects Analog out & Peak/Valley)	
Filter Settings	Off, Static, Dynamic FIR and/or Moving Average	
Serial Interfaces	USB 2.0 standard	
ENVIRONMENTAL		
Operating Temperature	°C	-10 to +45
	°F	+14 to 113
Relative Humidity – % MAX	at °C	10% to 90%, non-condensing
	at °F	10% to 90%, non-condensing
POWER		
Supply	VDC	24 VDC with supplied 120V 60Hz, AC/DC adapter or 9-36 VDC external supply
Power Consumption	W	6 RMS, 8 Peak
Switching frequency of internal PSU		300kHz
Provides isolation		6kV
MECHANICAL		
Dimensions - W x H x D	mm	106 x 66 x 150
	in	4.17 x 2.6 x 5.91
Weight	g	68
	lbs	1.5
Display – mm(in)		128 x 32 OLED dot matrix display. Font size is 9.5 (0.37) H and 6.5 (0.26) W
Panel Cutout - W x H	mm	91 x 46
	in	3.58 x 1.81
FAST ANALOG OUTPUT – kHz		VDC 0-5, 0-10, 2.5+/-2.5, 5+/-5 mA 4-20, 0-24, 12+/-8, 12 +/-12

Warranty

Warranty

All indicator products from Interface Inc., ('Interface') are warranted against defective material and workmanship for a period of (1) one year from the date of dispatch. If the 'Interface' product you purchase appears to have a defect in material or workmanship or fails during normal use within the period, please contact your Distributor, who will assist you in resolving the problem. If it is necessary to return the product to 'Interface' please include a note stating name, company, address, phone number and a detailed description of the problem. Also, please indicate if it is a warranty repair. The sender is responsible for shipping charges, freight insurance and proper packaging to prevent breakage in transit. 'Interface' warranty does not apply to defects resulting from action of the buyer such as mishandling, improper interfacing, operation outside of design limits, improper repair or unauthorised modification. No other warranties are expressed or implied. 'Interface' specifically disclaims any implied warranties of merchantability or fitness for a specific purpose. The remedies outlined above are the buyer's only remedies. 'Interface' will not be liable for direct, indirect, special, incidental or consequential damages whether based on the contract, tort or other legal theory. Any corrective maintenance required after the warranty period should be performed by 'Interface' approved personnel only

www.interfaceforce.com